

# KUSTOM<sup>®</sup>

## OWNER'S MANUAL KPM8420T



Congratulations on the purchase of your new Kustom amp! Your new KPM8420T Powered mixer successfully draws on more than 30 years of amplifier design and manufacturing experience at Kustom. This amp was planned from the ground up by our engineers to offer top-notch tone and dependable performance. Inside this manual, you'll find handy information about the amp's features. We wish you many years of enjoyment with your Kustom KPM8420T Powered Mixer.

# ENGLISH

## Danger

Exposure to extremely high noise levels may cause a permanent hearing loss. Individuals vary considerably to noise induced hearing loss but nearly everyone will lose some hearing if exposed to sufficiently intense noise for a sufficient time.

The U.S. Government's Occupational Safety and Health Administration (OSHA) has specified the following permissible noise level exposures:

DURATION PER DAY (HOURS)	8	6	4	3	2	1
SOUND LEVEL (dB)	90	93	95	97	100	103

According to OSHA, any exposure in the above permissible limits could result in some hearing loss. Ear plugs or protectors in the ear canal or over the ears must be worn when operating this amplification system in order to prevent a permanent hearing loss. If exposure in excess of the limits as put forth above, to insure against potentially harmful exposure to high sound pressure levels, it is recommended that all persons exposed to equipment capable of inducing high sound pressure levels, such as this amplification system, be protected by hearing protectors while this unit is in operation.

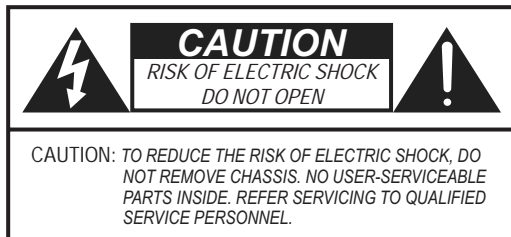

*AVIS: RISQUE DE CHOC ELECTRIQUE-NE PAS OUVRIIR.*



THIS SYMBOL IS INTENDED TO ALERT THE USER TO THE PRESENCE OF NON-INSULATED "DANGEROUS VOLTAGE" WITHIN THE PRODUCT'S ENCLOSURE THAT MAY BE OF SUFFICIENT MAGNITUDE TO CONSTITUTE A RISK OF ELECTRIC SHOCK TO PERSONS.



THIS SYMBOL IS INTENDED TO ALERT THE USER TO THE PRESENCE OF IMPORTANT OPERATING AND MAINTENANCE (SERVICING) INSTRUCTIONS IN THE LITERATURE ACCOMPANYING THE UNIT.



APPARATUS SHALL NOT BE EXPOSED TO DRIPPING OR SPLASHING AND THAT NO OBJECTS FILLED WITH LIQUIDS, SUCH AS VASES, SHALL BE PLACED ON THE APPARATUS.

## IMPORTANT SAFETY INSTRUCTIONS

1. Read all safety and operating instructions before using this product.
2. All safety and operating instructions should be kept for future reference.
3. Read and understand all warnings listed on the operating instructions.
4. Follow all operating instructions to operate this product.
5. This product should not be used near water, i.e. Bathtub, sink, swimming pool, wet basement, etc.
6. Only use dry cloth to clean this product.
7. Do not block any ventilation openings, It should not be placed flat against a wall or placed in a built-in enclosure that will impede the flow of cooling air.
8. Do not install this product near any heat sources ;such as,radiators, heat registers, stove or other apparatus (including heat producing amplifiers) that produce heat.
9. Do not defeat the safety purpose of the polarized or grounding-type plug. A polarized plug has two blades with one wider than the other.A grounding-type plug has two blades and a third grounding prong. The wide blade or the third prong are provided for your safety If the provided plug does not fit into your outlet, consult an electrician for replacement of the obsolete outlet.
10. Protect the power cord being walked on or pinched, particularly at Plugs, convenience receptacles and the point where they exit from the apparatus. Do not break the ground pin of the power supply cord.
11. Only use attachments specified by the manufacturer.
12. Use only with the cart, stand, tripod, bracket, or table specified by the manufacturer or sold with the apparatus. When a cart is used, use caution when moving cart/ apparatus combination to avoid injury from tip-over. 
13. Unplug this apparatus during lightning storms or when unused for long periods of time.
14. Care should be taken so that objects do not fall and liquids are not spilled into the unit through the ventilation ports or any other openings.
15. Refer all servicing to qualified service personnel. Servicing is required when the apparatus has been damaged in any way; such as, power-supply cord or plug is damaged, liquid has been spilled or objects have fallen into the apparatus, the apparatus has been exposed to rain or moisture, does not operate normally or has been dropped.
16. WARNING: To reduce the risk of fire or electric shock, do not expose this apparatus to rain or moisture.
17. The MAINS plug or an appliance coupler is used as the disconnect device, the disconnect device shall remain readily operable.

# FRENCH

## Danger

L'exposition a des niveaux eleves de bruit peut provoquer une perte permanente de l'audition, Chaque organisme humain reagit differemment quant a la perte de l'audition, mais quasiment tout le monde subit une diminution de l'acuite auditive lors d'une exposition suffisamment longue au bruit intense. Les autorites competentes en reglementation de bruit ont defini les expositions tolerees aux niveaux de bruits:

DURE EN HEURES PAR JOUR	8	6	4	3	2	1
INIVEAU SONORE CONTINU EN dB	90	93	95	97	100	103

Selon les autorites, toute exposition dans les limites citees ci-dessus, peuvent provoquer certaines pertes d'audition. Des bouchons ou protections dans l'appareil auditif ou sur l'oreille doivent etre portes lors de l'utilisation de ce systeme d'amplification afin de prevenir le risque de perte permanente de l'audition, Dans le cas d'expositions superieures aux limites precitees il est recommande, afin de se premunir contre les expositions aux pressions acoustiques elevees potentiellement dangeereuses, aux personnes exposees aux equipements capables de delivrer de telles puissances, tels ce systeme d'amplification en fonctionnement, de proteger l'appareil auditif.



CE SYMBOLE A POUR BUT D'AVERTIR L'UTILISATEUR DE LA PRESENCE DE VOLTAGE DANGEREUX NON-ISOLE A L'INTERIEUR DE CE PRODUIT QUI PEUT ETRE DE PUISSANCE SUFFISAMMENT IMPORTANTE POUR PROVOQUER UN CHOC ELECTRIQUE AUX PERSONNES.



CE SYMBOLE A POUR BUT D'AVERTIR L'UTILISATEUR DE LA PRESENCE D'INSTRUCTIONS D'UTILISATION ET DE MAINTENANCE DANS LES DOCUMENTS FOURNIS AVEC CE PRODUIT.



AFIN DE REDUIRE LES RISQUE D'INCENDIE ET DE DECHARGE ELECTRIQUE, NE PAS EXPOSER CET APPAREIL A LA PLUIE OU A L'HUMIDITE.

## IMPORTANTES INSTRUCTIONS DE SECURITE

1. Lire avec attention toutes les recommandations et precautions d'emploi avant d'utiliser ce produit.
2. Toutes les recommandations et precautions d'emploi doivent etre conservees afin de pouvoir s'y reporter si necessaire.
3. Lire et comprendre tous les avertissements eumeres dans les precautions d'emploi.
4. Suivre toutes les precautions d'emploi pour utiliser ce produit.
5. Ce produit ne doit pas etre utilise pres d'eau, comme par exemple baignoires, eviers, piscine, sous-sol humides ... Etc.
6. Utiliser exclusivement un chiffon sec pour nettoyer ce produit.
7. Ne bloquer aucune ouverture de ventilation. Ne pas placer le produit tout contre un mur ou dans une enceinte ferree, cela generait le flux d'air necessaire au refroidissement.
8. Ne pas placer le produit pres de toute source de chaleur telle que radiateurs, arrivees d'air chaud, fourneaux ou autres appareils generant de la chaleur (incluant les amplificateurs producteurs de chaleur) .
9. Ne pas negliger la securite que procure un branchement polarise ou avec raccordement a la terre, Un branchement polarise comprend deux fiches dont l'une est plus large que l'autre. Un branchement a la terre comprend deux fiches plus une troisieme reliee a la terre. Si la fiche secteur fournie ne s'insert pas dans votre prise de courant. consulter un 'electricien afin de remplacer votre prise obsolete.
10. Protger le cordon d'alimentation de tout ecrasement ou pincement, particulierement au niveau des fiches, des receptacles utilises et a l'endroit de sortie de l'appareil. Ne pas casser la fiche de terre du cordon d'alimentation.
11. Utiliser uniquement les accessoires specifies par le constructeur.
12. Utiliser uniquement avec le chariot de transport, le support, le trepied, la console ou la table specifies par le constructeur ou vendus avec l'appareil. Lors de l'utilisation d'un chariot, bouger avec precaution l'ensemble chariotlappareil afin d'eviter les dommages d'un renversement.
13. Debrancher cet appareil lors d'orages ou s'il n'est pas utilise pendant une longue periode.
14. Des precautions doivent etre prises afin qu'aucun objet ne tombe et qu'aucun liquide ne se repande a l'interieur de l'appareil par les orifics de ventilation ou n'importe quelle autre ouverture.
15. Pour toutes interventions techniques s'adresser a un technicien qualifie. L'intervention technique est necessaire lorsque l'appareil a ete endommage de n'importe quelle facon, comme par exemple si le cordon secteur ou sa fiche sont deteries, si du liquide a coule ou si des objets sont tombes a l'interieur de l'appareil, si l'appareil a ete expose a la pluie ou a l'humidite, s'il ne fonctionne pas normalement ou s'il est tombe.
16. ATTENTION: Pour reduire le risque d'incendie ou de choc electrique ne pas exposer l'appareil a la pluie ou a l'humidite.
17. La prise Mains, au coupler, est utilise pour la source d'alimentation electrique. Il est conseille de garder cette prise facilement accessible.



# Front and Rear Panel Layout

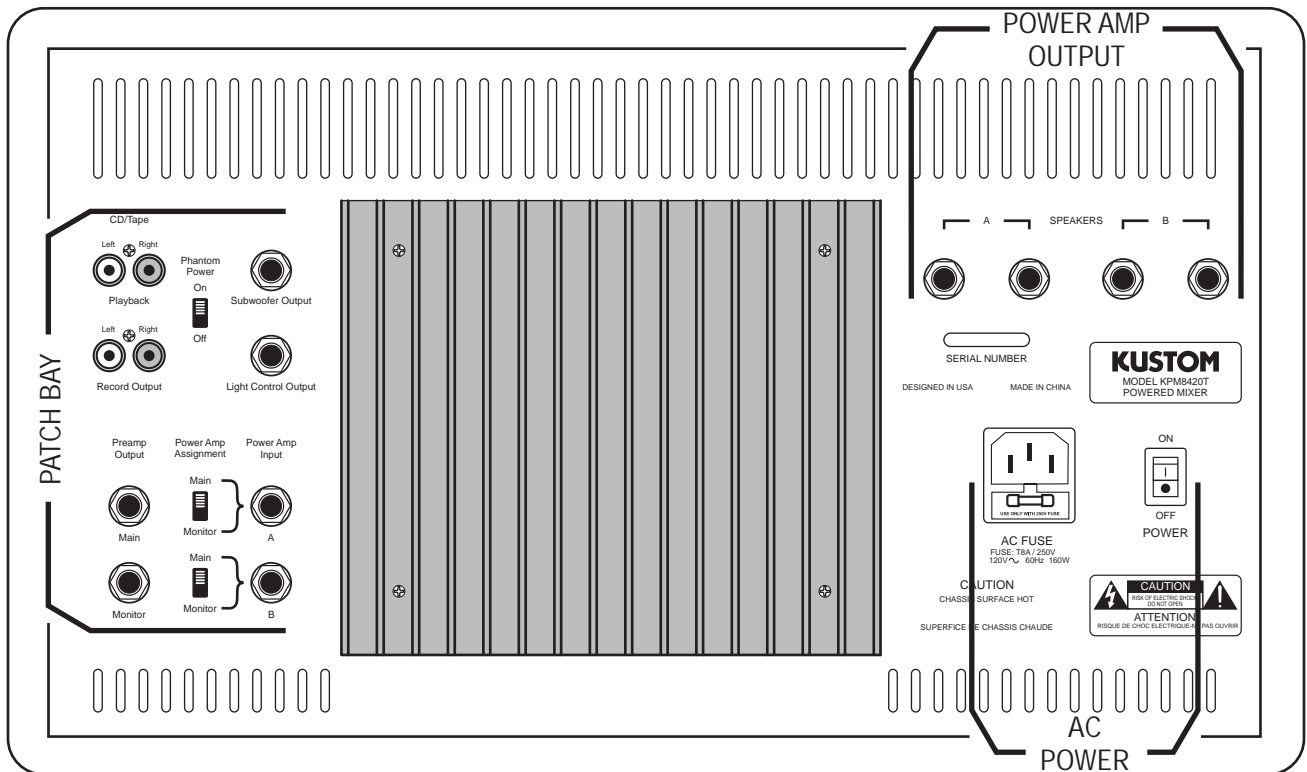
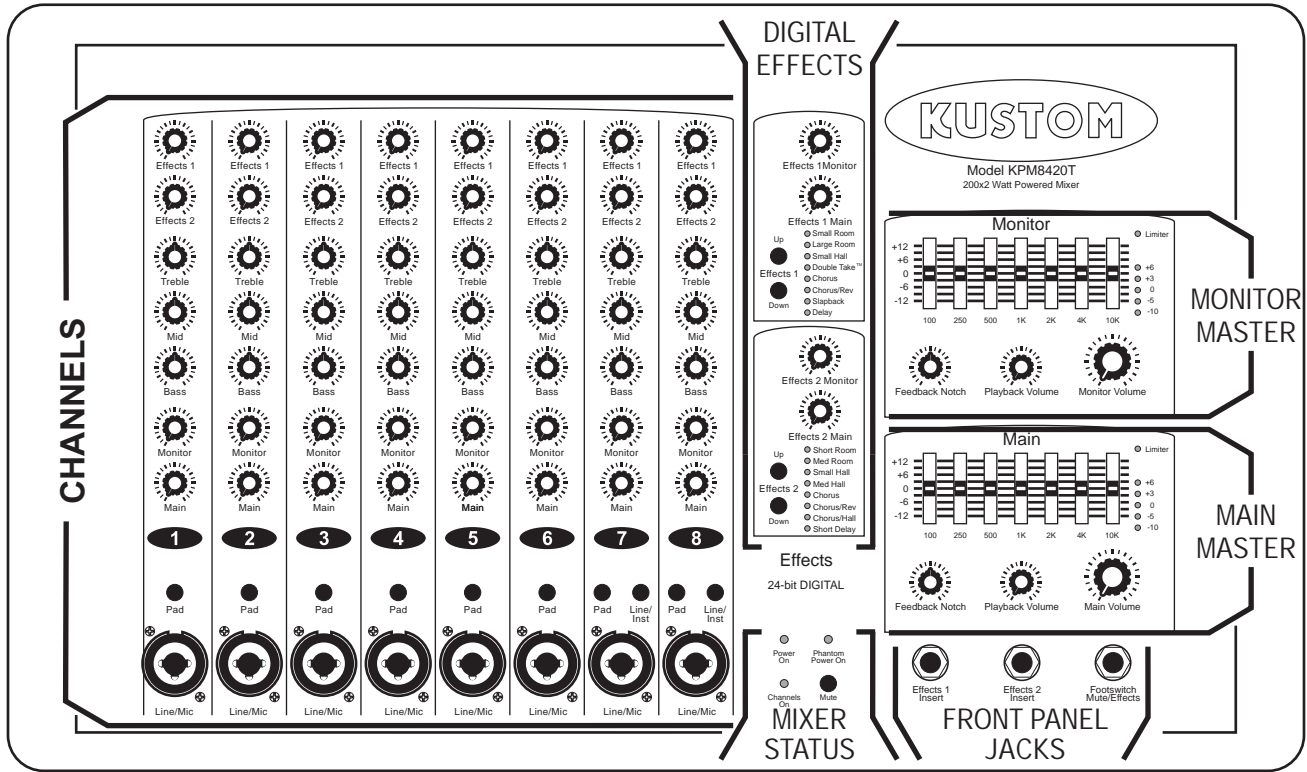

# CHANNELS

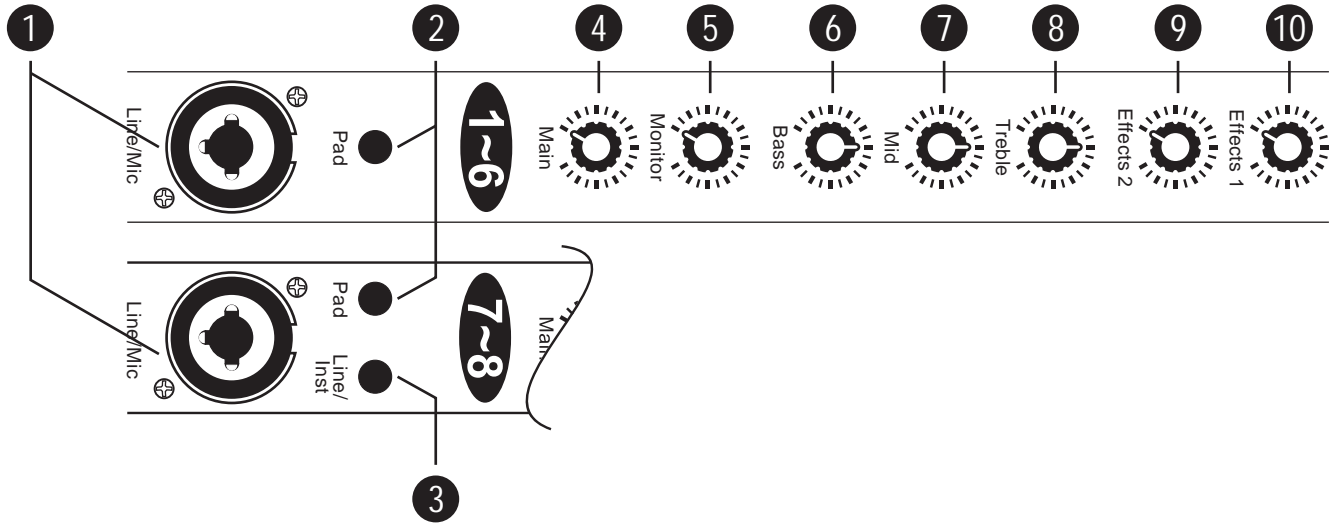

## 1 LINE/MIC Input Jacks:

These are combination input jacks capable of receiving a Male-XLR for Balanced inputs such as microphones or a Male 1/4" Plug for Line level and Instrument level devices.

## 2 PAD Switch:

This switch attenuates the input signal by 12db in the out position. Press in when more input signal gain is needed. If the input sounds distorted, then use the out position.

## 3 LINE/INSTRUMENT Buttons (Channels 7&8 Only):

When the button is out, the 1/4" input is configured to receive a standard Line level input such as a High-Z microphone, keyboard, drum machine, etc. When this button is pressed, the input is configured to receive an input from an electric or acoustic guitar. No additional preamps are necessary to amplify acoustic guitars with piezo pickups.

## 4 MAIN Volume Control:

Adjusts the volume of the individual channels to the MAIN output section.

## 5 MONITOR Volume Control:

Adjusts the volume of the individual channels to the MONITOR output section.

## 6 BASS Control:

Adjusts the amount of bass or low frequencies of the individual channels to the main output section. (NOTE: This control does not affect the monitor signal).

## 7 MID Control:

Adjusts the amount of mid-range frequencies of the individual channels to the main output section. (NOTE: This control does not affect the monitor signal).

## 8 TREBLE Control:

Adjusts the amount of Treble or high frequencies of the individual channels to the main output section. (NOTE: This control does not affect the monitor signal).

## 9 EFFECTS 2 Control:

This control adjusts the amount of signal sent to the EFFECTS 2 master section. Note: This control is post fader, meaning the Effects 2 control gets its signal from the MAIN volume control. The MAIN volume control must be turned up to allow signal to flow to the EFFECTS 2 Control.

## 10 EFFECTS 1 Control:

This control adjusts the amount of signal sent to the EFFECTS 1 master section. Note: This control is post fader, meaning the Effects 1 control gets its signal from the MAIN volume control. The MAIN volume control must be turned up to allow signal to flow to the EFFECTS 1 Control.

# DIGITAL EFFECTS

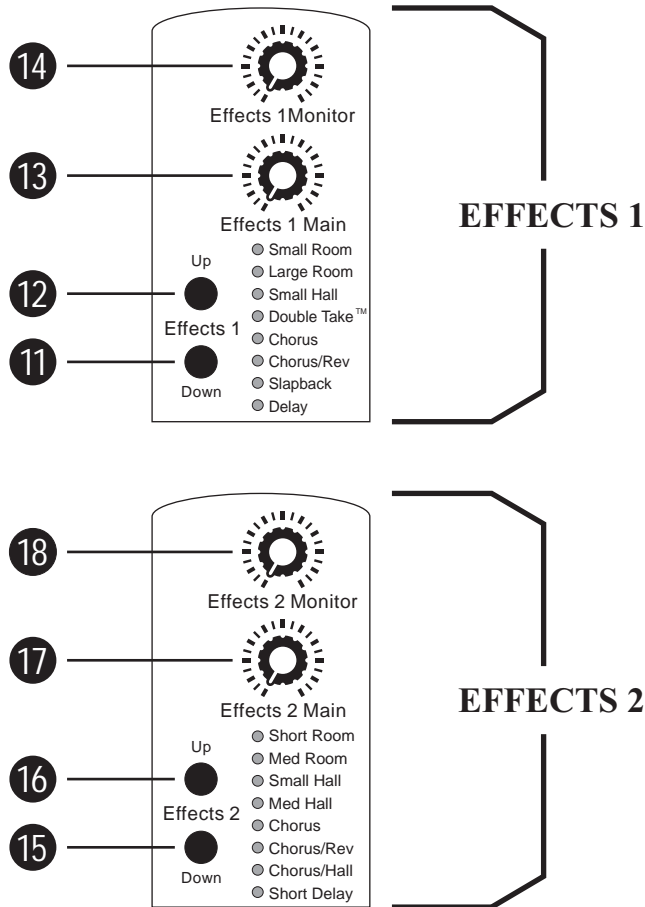

## EFFECTS 1

## EFFECTS 2

- 11 EFFECTS 1 DOWN Button:**  
This button scrolls down through the Digital Effects sounds. Pressing this button when the (Echo) effect is lit will result in resetting the selected sound to the top (Small Room).
- 12 EFFECTS 1 UP Button:**  
This button scrolls up through the Digital Effects sounds. Pressing this button when the (Small Room) effect is lit will result in resetting the selected sound to the bottom (Echo).
- 13 EFFECTS 1 MAIN Control:**  
This controls the amount of Effects 1 that is sent to the MAIN Master Section.
- 14 EFFECTS 1 MONITOR Control:**  
This controls the amount of Effects 1 that is sent to the MONITOR Master Section.

- 15 EFFECTS 2 DOWN Button:**  
This button scrolls down through the Digital Effects sounds. Pressing this button when the (Short Delay) effect is lit will result in resetting the selected sound to the top (Short Room).
- 16 EFFECTS 2 UP Button:**  
This button scrolls up through the Digital Effects sounds. Pressing this button when the (Short Room) effect is lit will result in resetting the selected sound to the bottom (Short Delay).
- 17 EFFECTS 2 MAIN Control:**  
This controls the amount of Effects 2 that is sent to the MAIN Master Section.
- 18 EFFECTS 2 MONITOR Control:**  
This controls the amount of Effects 2 that is sent to the MONITOR Master Section.

## MAIN AND MONITOR MASTER

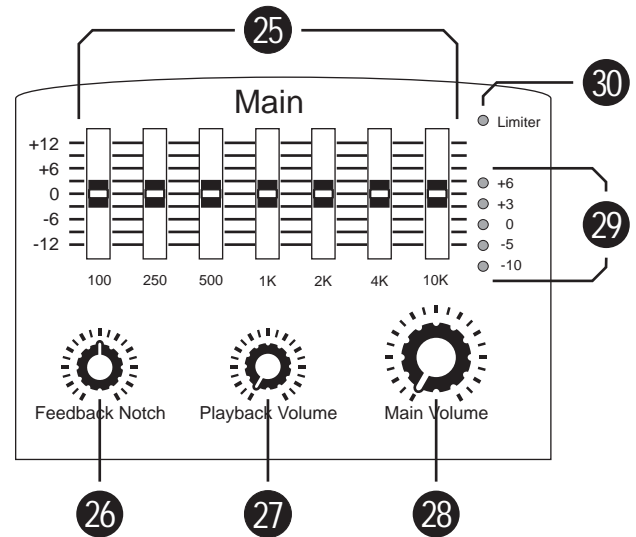
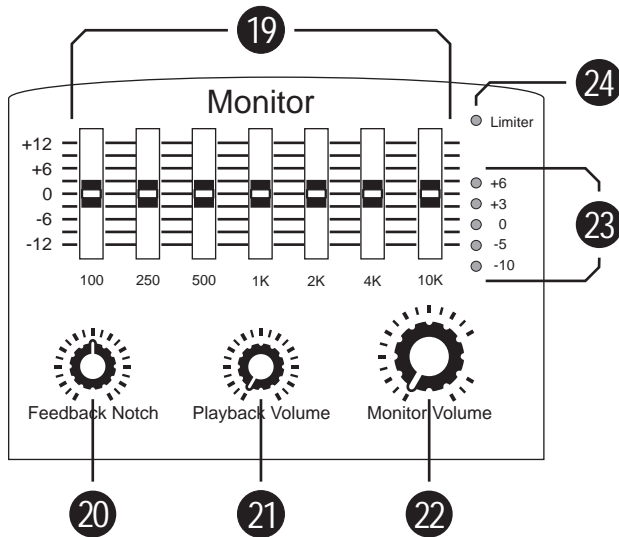

### MONITOR MASTER

- 19 MONITOR MASTER GRAPHIC EQ:**  
This set of slide controls adjusts specific frequencies in order to tailor the overall sound to an acoustical environment or an intended sound.
- 20 FEEDBACK NOTCH (MONITOR):**  
This control is a narrow notch that can remove a problem frequency that may causing excessive feedback. To activate this feature, slowly turn the control to find the feedback problem area. This subtlety turns down a small area of frequencies, thus removing the feedback without greatly affecting the overall sound. Turning this knob full counter-clockwise will defeat the feedback filter.
- 21 PLAYBACK VOLUME (MONITOR):**  
This control adjusts the amount of input from the Playback input jacks (Rear Panel). This set of Stereo RCA jack will accept any Line-Level audio sources such as: CD, MP-3, DVD, HARD DISC & TAPE PLAYER. NOTE: This controls passes signal directly to the MONITOR Master section and is not affected by the Channels ON/MUTE function.
- 22 MONITOR MASTER Control:**  
This control adjusts the master volume of the Monitor section.
- 23 MONITOR LED METER:**  
This indicates the level of Monitor Preamp output. The number values are in dBV (1VRMS = 0dBV).
- 24 LIMITER LED:**  
This indicates Power Amp A has reached full clean output. If the input signal to the power amp increases after the LED is lit, it will be limited to protect the speakers. Because this limiter is built into Power Amp A, the LED only shows that the monitors are at full output when assigned to it (See page 9 for information on assigning power amps).

### MAIN MASTER

- 25 MAIN MASTER GRAPHIC EQ:**  
This set of slide controls adjusts specific frequencies in order to tailor the overall sound to an acoustical environment or an intended sound.
- 26 FEEDBACK NOTCH (MAIN):**  
This control is a narrow notch that can remove a problem frequency that may causing excessive feedback. To activate this feature, slowly turn the control to find the feedback problem area. This subtlety turns down a small area of frequencies, thus removing the feedback without greatly affecting the overall sound. Turning this knob full counter-clockwise will defeat the feedback filter.
- 27 PLAYBACK VOLUME (MAIN):**  
This control adjusts the amount of input from the Playback input jacks (Rear Panel). This set of Stereo RCA jack will accept any Line-Level audio sources such as: CD, MP-3, DVD, HARD DISC & TAPE PLAYER. NOTE: This controls passes signal directly to the MONITOR Master section and is not affected by the Channels ON/MUTE function.
- 28 MAIN MASTER Control:**  
This control adjusts the master volume of the Main section.
- 29 MAIN LED METER:**  
This indicates the level of Main Preamp output. The number values are in dBV (1VRMS = 0dBV).
- 30 LIMITER LED:**  
This indicates Power Amp B has reached full clean output. If the input signal to the power amp increases after the LED is lit, it will be limited to protect the speakers. Because this limiter is built into Power Amp B, the LED only indicates the Mains are at full output when assigned to it (See page 9 for information on assigning power amps).

# MIXER STATUS AND FRONT PANEL JACKS

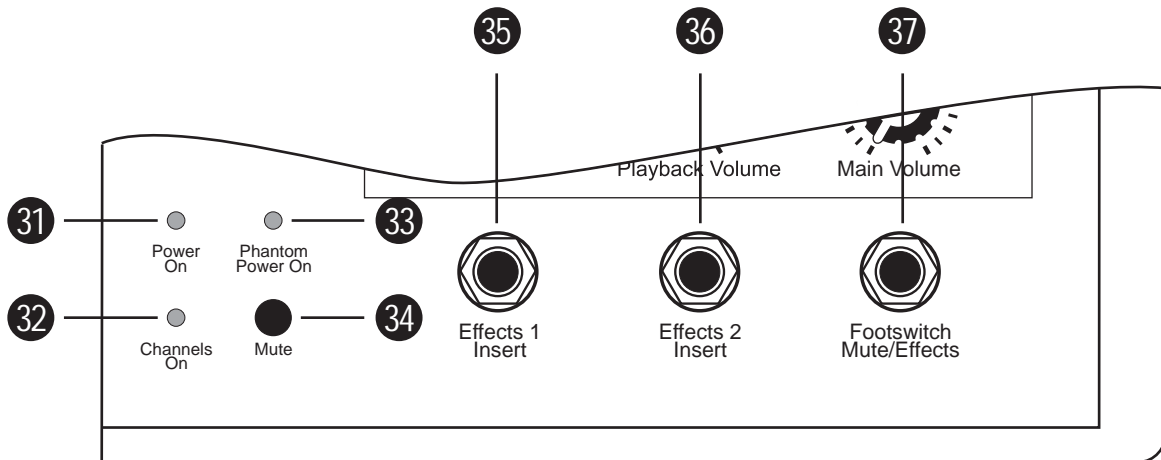

## MIXER STATUS

- 31 POWER ON LED:**  
When lit, power is being delivered to the mixer.
- 32 CHANNELS ON LED:**  
When lit, the channels will deliver signal to the master sections.
- 33 PHANTOM POWER LED:**  
When lit, this LED indicates that Phantom power is being delivered to the XLR jacks.
- 34 MUTE Button:**  
When pressed, this button will MUTE the input channels. This switch is defeated when the footswitch jack is used. NOTE: Playback inputs will still function when channel mute is on.

## FRONT PANEL JACKS

- 35 EFFECTS 1 INSERT Jack:**  
This 1/4" STEREO jack allows an external effect to be used with your KPM8420T. Ring = Effects Send. Tip = Effects Return. NOTE: using insert jacks will not disable internal effects.
- 36 EFFECTS 2 INSERT Jack:**  
This 1/4" STEREO jack allows an external effect to be used with your KPM8420T. Ring = Effects Send. Tip = Effects Return. NOTE: using insert jacks will not disable internal effects.
- 37 FOOTSWITCH (MUTE/EFFECTS):**  
This 1/4" Stereo jack accesses the Channel Mute and Effects On/Off Functions. TIP = Effects Mute. RING = Channel Mute. Suggested footswitch = Kustom KAC FS202

# PATCH BAY

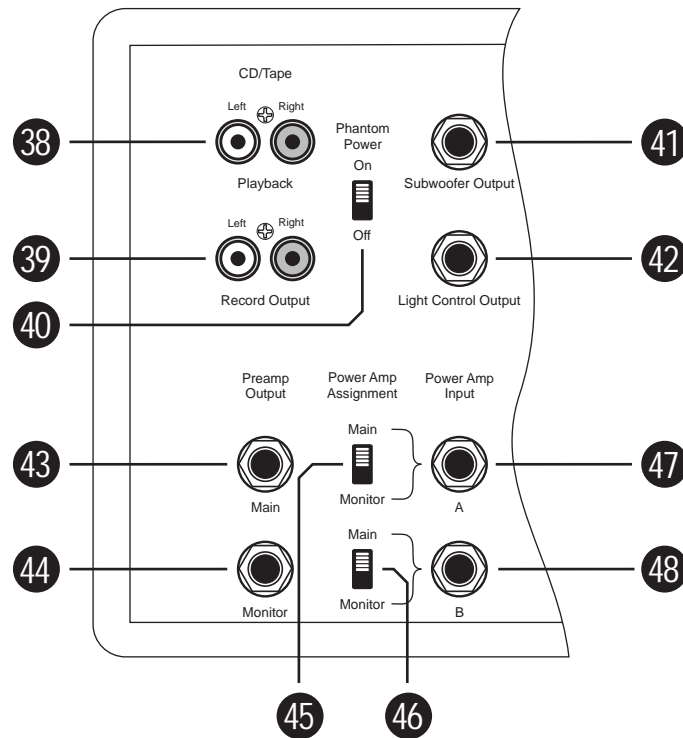

**38 CD / TAPE PLAYBACK Jacks:**

These RCA jacks are used to play audio from CD, Tape, Computer, DVD, Hard Disc, MP-3 or other line level audio source. NOTE: Use the PLAYBACK controls (#21 & #27) to adjust the volume of the playback to the Main and Monitor sections.

**39 CD / TAPE RECORD OUTPUT Jacks:**

These RCA jacks deliver a MONO Line level output to a recording device such as Tape Recorder, Computer, Recordable DVD, Hard Disc, MP-3 and more.

**40 PHANTOM ON/OFF Switch:**

This switch turns on the 40V phantom power to the XLR input Jacks. This power supply is designed to provide power for condenser microphones and other devices.

**41 SUB WOOFER OUTPUT Jack:**

This is a low pass sub woofer output. Crossover point = 150 hz @ 12db/oct.

**42 LIGHT CONTROLLER OUTPUT Jack:**

This is selective band-pass output designed to deliver a Line level audio trigger signal to Lighting Controller devices.

**43 PREAMP OUTPUT MAIN:**

This 1/4" Mono jack delivers a Line level output from the MAIN Master section.

**44 PREAMP OUTPUT MONITOR:**

This 1/4" Mono jack delivers a line level output from the MONITOR Master section.

**45 POWER AMP ASSIGN A Switch:**

This switch determines which master section will drive the A power-amp. Place the switch in the UP position to have the MAIN mix signal to the A power-amplifier. Place the switch in the down position to have the MONITOR mix signal to the A power-amplifier.

**46 POWER AMP ASSIGN B Switch:**

This switch determines which master section will drive the B power-amp. Place the switch in the UP position to have the MAIN mix signal to the B power-amplifier. Place the switch in the down position to have the MONITOR mix signal to the B power-amplifier.

**47 POWER AMP INPUT A:**

This 1/4" Mono jack allows the A power-amplifiers to be used with an external Line level input. NOTE: When used, this jack will interrupt the signal flow from the mixer section of the KPM8420T.

**48 POWER AMP INPUT B:**

This 1/4" Mono jack allows the B power-amplifiers to be used with an external Line level input. NOTE: When used, this jack will interrupt the signal flow from the mixer section of the KPM8420T.

## POWER AMP OUTPUTS, AC POWER

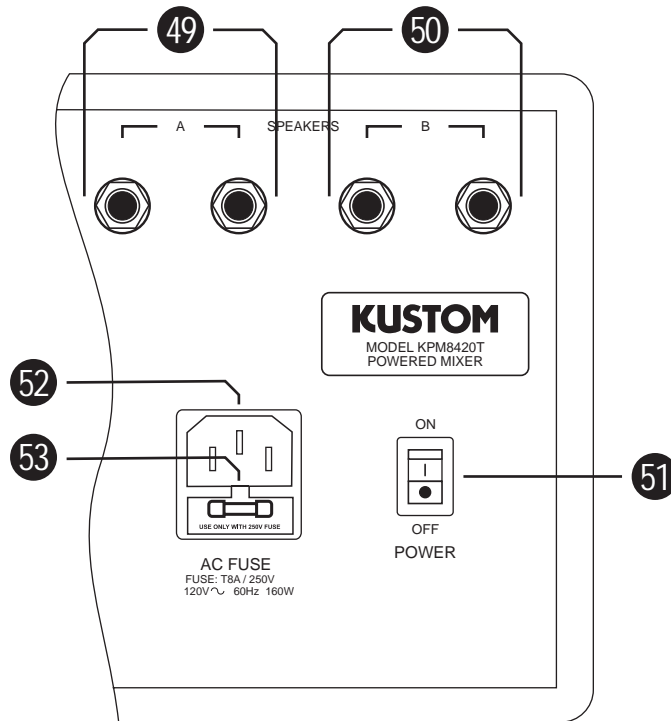

### POWER AMP OUTPUT

**49 SPEAKERS A:**  
These two 1/4" jacks deliver the power from the A power-amp to the speakers.

**50 SPEAKERS B:**  
These two 1/4" jacks deliver the power from the B power-amp to the speakers.

**MINIMUM LOAD (Impedance) Per Channel:**  
4 OHMS

**POWER RATING Per Channel:**  
200 Watts@4 ohms, 125 Watts@8 ohms. Both amps driven to 100%

**Caution:** Use speakers rated at 125 Watts @ 8 ohms or higher. Severe damage to the speakers is possible if too low of wattage speaker is used.

### AC POWER

**51 POWER ON / OFF Switch:**  
The KPM8420T is ON when the switch is in the UP position. Press the switch to the DOWN position to turn the KPM8420T off. Always remove the AC plug from the wall when not in use.

**52 AC Power Cord Receptacle:**  
Insert the AC cord (Provided) firmly into the AC connector. NOTE: Replace the AC power cord if protective jacket is damaged or ground pin is damaged or removed.

**53 FUSE:**  
The fuse is located in a housing just below the receptacle. Replace only with same type and size. To remove the fuse, pull the tab located above the fuse symbol away from the fuse housing.

# FAQ Frequently Asked Questions:

## 1. How many speakers can I use with the KPM8420T?

*ANSWER: Most speaker cabinets today are 8-ohms. For the sake of this question we will assume this is the case. You can use a total of four 8-ohm speakers with the KPM8420T: Two for the A power-amp ④ and two for the B power-amp ⑤. DO NOT plug all four speakers into one power-amp.*

## 2. Can I use two different effects on my vocal mics?

*ANSWER: Yes! One popular setting for vocal mics is to use one digital effects section for reverb and the other effects section for delay. Here is an example: Set Effects 1 to ECHO and Effects 2 to SMALL HALL. Adjust the amount of reverb first by turning up the EFFECTS 2 control on the desired individual channel. Then, add the desired amount of ECHO by turning up the EFFECTS 1 control on the same individual channel. Set levels to obtain the desired effect.*

## 3. Can I use one effects section for my vocals and the other for my instruments?

*ANSWER: Yes! This is one of the truly unique features of the KPM8420T. Here is an example: a little Chorus on an instrument can really sweeten the sound, but chorus effects on vocals are a disaster. First set up the Instrument channels: Set the sound of EFFECTS 2 to Chorus or Chorus/Rev in the master section of the mixer. Turn up the EFFECTS 2 send on the individual instrument channels to the desired level. Now the vocal channels: Set the sound of EFFECTS 1 to one of the reverb selections. Turn up the EFFECTS 1 send on the individual vocal channels to the desired level.*

## 4. Can I use a sub-woofer without using the fixed crossover from the KPM8420T?

*ANSWER: Yes! Use the MAIN preamp output jack ③ to feed a full range main signal to your sub-woofer or active crossover and power-amp.*

## 5. Can I use both Power-amps for mains or monitors?

*ANSWER: Yes! To use both power-amps for mains, set the POWER AMP ASSIGNMENT switches ④⑤ & ④⑥ to the UP (MAIN) position. To use both power-amps for monitors, set the POWER AMP ASSIGNMENT switches (#41&#42) to the DOWN (MONITOR) position.*

## 6. Can I use another non-powered mixer with my KPM8420T to get more channels?

*ANSWER: YES! Take the Line level output of the*

*external non-powered mixer and connect to one of the LINE ¼" inputs ①. Make sure the pad switch ② is NOT pressed in. Set the individual channel tone control to the twelve o'clock position and bring up the channel volume control as needed.*

## 7. Can I use an external Power-amp with my KPM8420T?

*ANSWER: Yes! For MAIN Master feed, connect a shielded high-Z instrument cable from the Preamp output MAIN jack ③ to the Line level input of the desired external power-amp.*

## 8. Not all of my microphones are condenser type. Will using the Phantom Power in the KPM8420T damage my non-condenser mics?

*ANSWER: No. You can safely use a combination of condenser and dynamic microphones at the same time.*

## 9. I have the Digital Effects Control knobs on Channel and Monitor turned up but still do not hear any effects through the monitors. Why?

*ANSWER: The Main volume ④ on the channel is not turned up. Because the effects send from the channels is Post Main, there must be signal present at that channels main output.*

## 9. I have a channel that I want in the Mains but not in the monitors. The Monitor Volume on the channel is all the way down but still comes through the monitors. Where is this coming from?

*ANSWER: It is coming from one or both of the Digital Effect Monitor controls ⑭ & ⑮ along with one or both of the channel Effect controls ⑨ & ⑩ being turned up. Fix the problem by turning down Effect 1 ⑩ or 2 ⑨ on the channel, or Effect 1 Monitor ⑭ or Effect 2 Monitor ⑮ on the digital effect.*

# KPM8420T

## Specifications

Model	KPM8420T	8 Channel Dual Powered Mixer
Output Power	200W per channel	4 Ohms @ 5% THD
	180W per channel	4 Ohms @ 0.4% THD
Frequency Response	20HZ-20kHz	Actual response is tailored to speaker cabinet for accurate acoustical response.
Total Harmonic Distortion	Less than 0.4%	Measured at 1VRMS (0dBv) at record output, effects send, preamp output, or Main output.
Hum & Noise	-115dB	Mic Input, Rs=150 ohm, 20-20kHz
	-55dB	Residual Noise, all level controls 0% (minimum)
	-45dB	Nominal System Noise, all level controls at 50%
System Gain	All Measurements made at 1kHz	
	90 dB	Mic to Power Amp (Ch 1 - Ch8) Pad Off
	77dB	Mic to Power Amp (Ch 1 - Ch8) Pad On
	72dB	Line to Power Amp (Ch 1 - Ch8) Pad Off
	60dB	Line to Power Amp (Ch 1 - Ch8) Pad On
	36dB	Playback to Power Amp
	50dB	Mic to Main out, Pad On
	50dB	Mic to Monitor out, Pad On
	50dB	Mic to Record out, Pad On
Crosstalk	70dB	Channel to Channel, 1kHz
Input Channel Equalization	Special curve that adjusts Bass, Mid, and Treble frequencies	
Master Equalization	100 to 10kHz, 7 Band, 1 Octave Graphic, all $\pm 12$ dB	
Digital Effects	Two 24 bit DSP modules, 8 effects per module.	
	Module 1: Small Room, Large Room, Small Hall, Double Take , Chorus, Chorus Reverb, Slapback, Delay	
	Module 2: Short Room, Med Room, Small Hall, Med Hall, Chorus, Chorus Reverb, Chorus Hall, Short Delay	
Phantom Power	+40V	Applied to all Mic inputs when active
Footswitch	Digital effects On/Off and Channel ON/OFF (playback remains active)	
	Recommended: KUSTOM model KAC-FS-202 (dual switch with LEDs)	
Power Requirements	USA/Canada	120VAC/60Hz, 300W nominal
	Europe	230VAC/50Hz, 300W nominal
	UK	230VAC/50Hz, 300W nominal
	Australia	240VAC/50Hz, 300W nominal
	Japan	100VAC/50-60Hz, 300W nominal
Dimensions	mm/kg	292 (Height) x 495 (Width) x 305 (Depth), 15.6kg
	Inches/Pounds	11.5 (Height) x 19 (Width) x 12.1 (Depth), 34.4 lbs

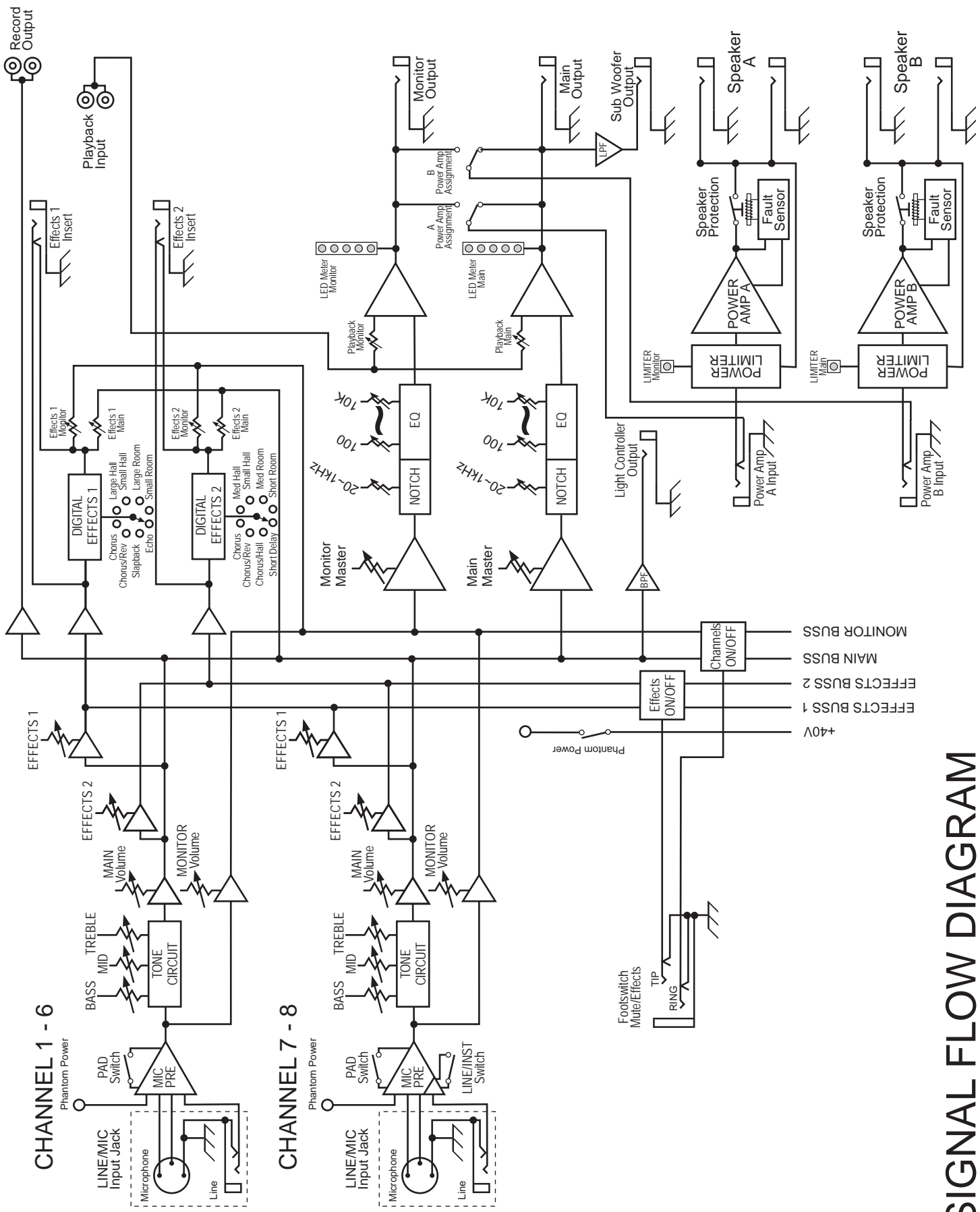

SIGNAL FLOW DIAGRAM

# EC Declaration of Conformity

We: Kustom Musical Amplification Inc.  
PO. Box 568  
Hebron, Ky 41048-0568  
Tel: 1-859-817-7100 Fax: 1-859-817-7150

Declare that the product

Product name: Kustom

Product model number: KPM8420T

to which this declaration relates is in conformity with the following standards;

EN55013 (A12) : 1995	Limits and methods of measurement of radio disturbance characteristics of broadcast receivers and associated equipment.
EN55020: 1995	Electromagnetic immunity of broadcast receivers and associated equipment.
EN61000-3-2: 1995	Limits for harmonic current emissions (equipment input current $\leq$ 16A per phase).
EN61000-3-3: 1995	Limitation of voltage fluctuations and flicker in low voltage supply systems for equipment with rated currents $\leq$ 16A.
EN55103-1: 1995	Electromagnetic Compatibility - Product family standard for Audio, Video Audio-visual and entertainment Lighting Control Apparatus.
EN60065: 1994	Safety requirements for main operated electronic and related apparatus for household and similar general use.

Following the provisions of EU Council Directive(s): 72/73 EEC and 89/336/EEC.

We the undersigned, hereby declare that the equipment specified above conforms to the aforementioned directive(s).

Name of authorized person: Rick Kukulies, VP Engineering

Signature: 

Date: 05 June 2001

Kustom Amplification Inc.  
PO. Box 568  
Hebron, Ky 41048-0568  
Tel: 1-859-817-7100 Fax: 1-859-817-7150



**KUSTOM**<sup>®</sup> Kustom Amplification Inc., PO BOX 568, Hebron, KY • USA  
888-4-KUSTOM (888-458-7866) Web: [www.kustom.com](http://www.kustom.com)

